

Model : HC250B-9					
Torque at 1000psi	300kg-m	2169 lb.ft	Stroke	229mm	9 inch
Cylinder Bore	63mm	2 1/2 inch	Volume	600cc	36.6 cu.in
Shaft Diameter	25mm	1 inch	Shaft Connection	SS Ball Joint (3/4"Hole)	

Note:SS inserts available for 1/2" & 3/8" & 5/8" Bolts 

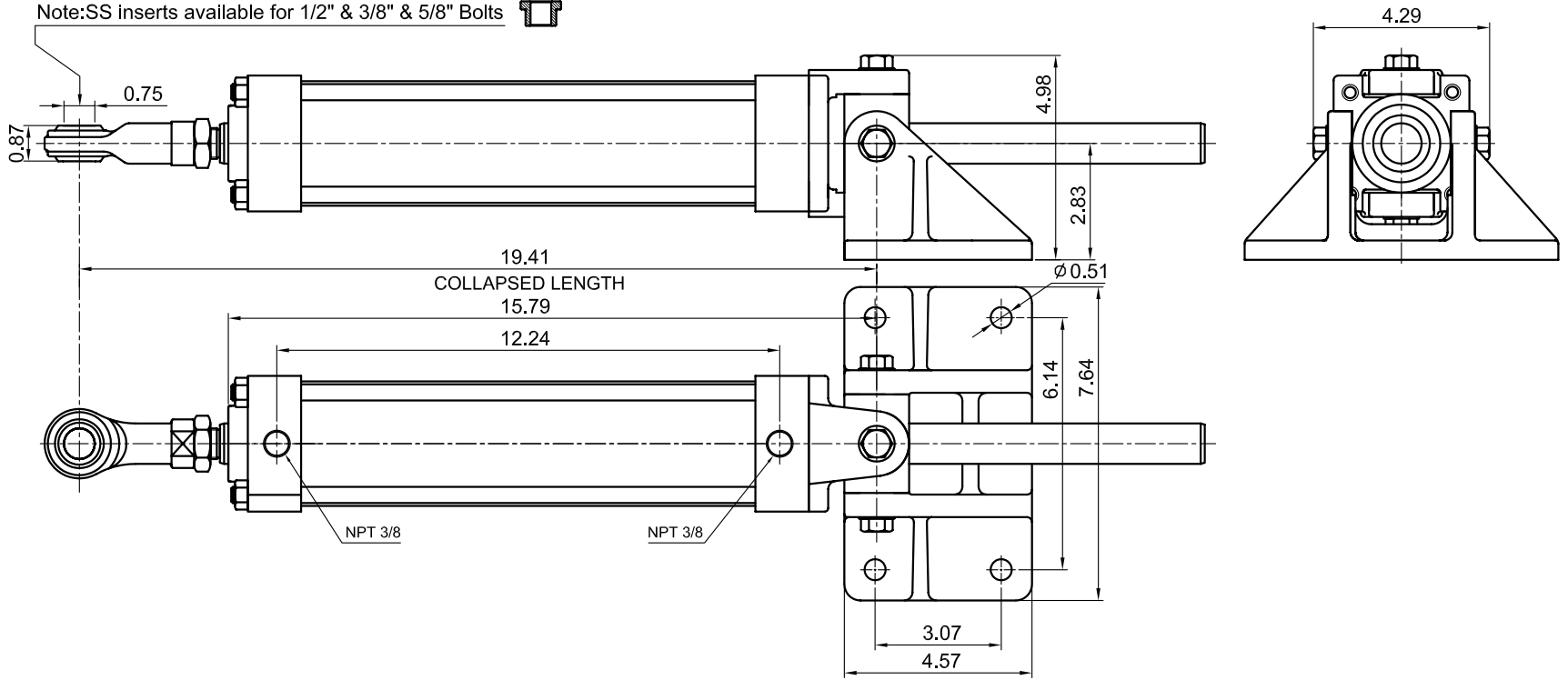

Model : HC250B-9 35°

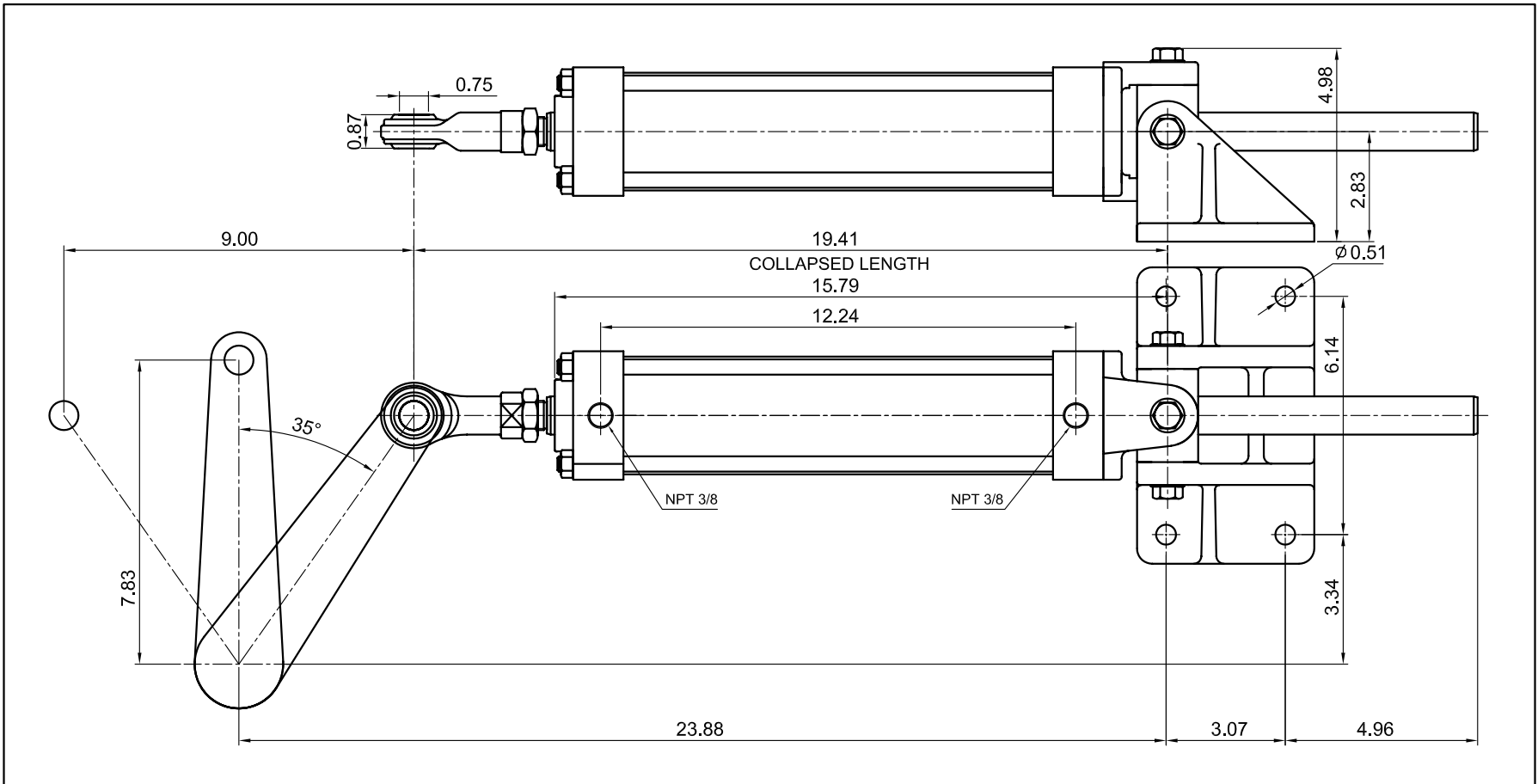

Model : HC250B-9 45°

